

PLANS FOR 1982-1992 CAMARO/FIREBIRD REAR WELL SUBWOOFER ENCLOSURE

MODEL M-1

Congratulations on your purchase! If for any reason you are unsatisfied with this plan set, or have suggestions on how to improve it, please contact us at Feedback@subenclosures.com.

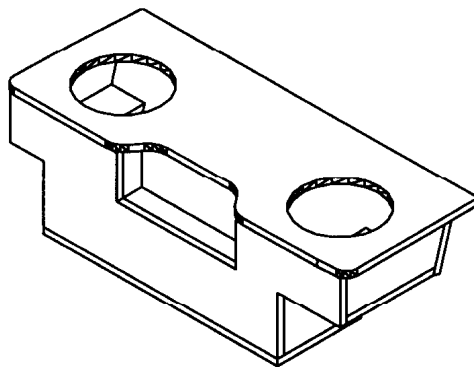

Specs:

Weight: 51lbs (Approx.)

Airspace: 2.075 cu.ft.

Accommodations: From (1) 8" subwoofer to (2) 12" subwoofers.

Top Mount Depth: 5-1/4" (can be easily modified to 6")

Materials you will need:

(1) Sheet 3/4" MDF (Not particle board!)

(80) Wood screws (1-5/8" long, coarse thread, drywall or other)

(1) Tube Liquid Nails Heavy Duty or equivalent

Speaker Terminals

Tools Recommended:

Table Saw or Circular Saw

Router (not necessary but helpful)

Jigsaw

Drill

Screw Driving Bit

Countersink Bit

Measuring Tape

Straight Edge

These plans are the sole property of SUBENCLOSURES.COM. Any reproduction of this plan set or any portion thereof without written consent is a violation of copyright law.

DISCLAIMER

These instructions are written under the assumption that the person following them has some prior general woodworking experience. All dimensions, angles, and sequences can be freely modified at the users discretion. The guidelines set forth are based on real world experience with this specific box, and this specific make and model of car.

Assurances:

These plans if followed correctly will yield a subwoofer enclosure that will fit within the rear hatch of a 1991 Camaro RS. It is implied that this design will also fit all other 1982-1992 Camaro's and Firebird's, however if a condition exists that requires some modification of the design to fit into your particular car, those modifications will be the responsibility of the builder.

The dimensions and build sequence outlined in these plans have been used successfully to create quality subwoofer enclosures that fit nicely and securely into 1982-1992 Camaro's and Firebird's.

If any problems or discrepancies arise through the use of these plans, please try to resolve these conflicts through our feedback E-mail address at: feedback@subenclosures.com.

Exemptions:

Neither SUBENCLOSURES.COM, nor it's proprietor or associates shall be liable for any damage caused as a result of using these plans.

SUBENCLOSURES.COM will not be responsible for the dissatisfaction of any completed enclosure if the source of the dissatisfaction is related in any way to the build quality.

CONSTRUCTION TIPS

If you're not familiar with MDF, it will be helpful to read through these tips. MDF has a tendency to split along the edges very easily if you're not careful. I've found that by following some simple guidelines, the chance of splitting the edges is almost eliminated. A slight cracking between pilot holes is nothing to really worry about. If however, there is splitting at a corner, or a split that cracks the surface of the wood, that piece should be re-cut to ensure maximum structural integrity. Using old, or weathered MDF increases the likelihood of splitting.

Pre-Drilling:

1. Drill pilot holes between 85% and 90% of the root diameter of the screw used and at least as deep as the screw.

#6 screws with a 3/32" pilot hole.

#8 screws with a 7/64" pilot hole.

#10 screws with a 1/8" pilot hole.

Placing Screws:

1. In most cases, screws can be safely placed within 1-1/2" of the edge of a piece of MDF. I recommend keeping them 2" from the edge unless the piece is too small to allow that. On pieces that have more than just a screw at each edge, I usually space the screws evenly somewhere between 3" and 4" apart. This will allow you to put plenty of pressure on the joint without having a tendency to split the wood.
2. Before drilling the pilot hole, I recommend drawing a line 3/8" from the edge of the wood along the joint. This will serve as a guide to ensure you are centering the screws on the piece being screwed into.

Using Sealant:

1. Remember that once you have applied sealant to the joint, it is very difficult to remove it. I recommend pre-drilling and test fitting each piece before applying sealant. Once the sealant is applied be very careful to align the pieces before screwing them together. Wood screws will still go into MDF without a pilot hole, and it will likely split the wood. Once the pieces are aligned, put one screw in at a corner without tightening it, then put another screw loosely in the other corner. Now that the piece won't shift, you can drive the other screws into place. Finally UNSCREW, and then re-screw the first corner screws. This will better seat the joint and compress the sealant.
2. While not structurally important, make sure you smooth out any sealant that has been pushed out of the joint as soon as possible. Some sealants start to dry very quickly. While smoothing out the excess sealant, try to make sure there is a uniform seam along the inside edges of the enclosure. That will help to ensure an airtight enclosure once the sealant dries.

Cutting:

1. MDF can be cut with any wood cutting blade, however some very coarse blades can chew up the edges. Best results are achieved by using a carbide blade in good condition.
2. It's good practice to cut only a few pieces at a time instead of cutting all of the pieces in the beginning. By cutting a few at a time, you can make up for any errors in previous cuts.

CUT SHEET

Recommended Piece Layout on 4'x8' sheet of MDF

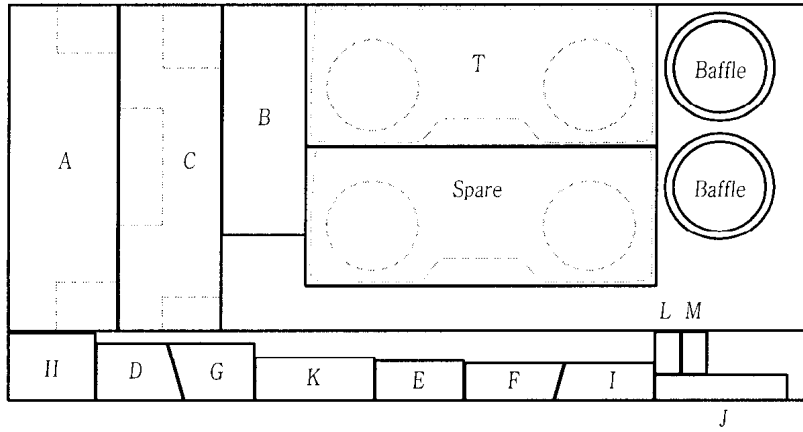

Pieces Relative to Assembly

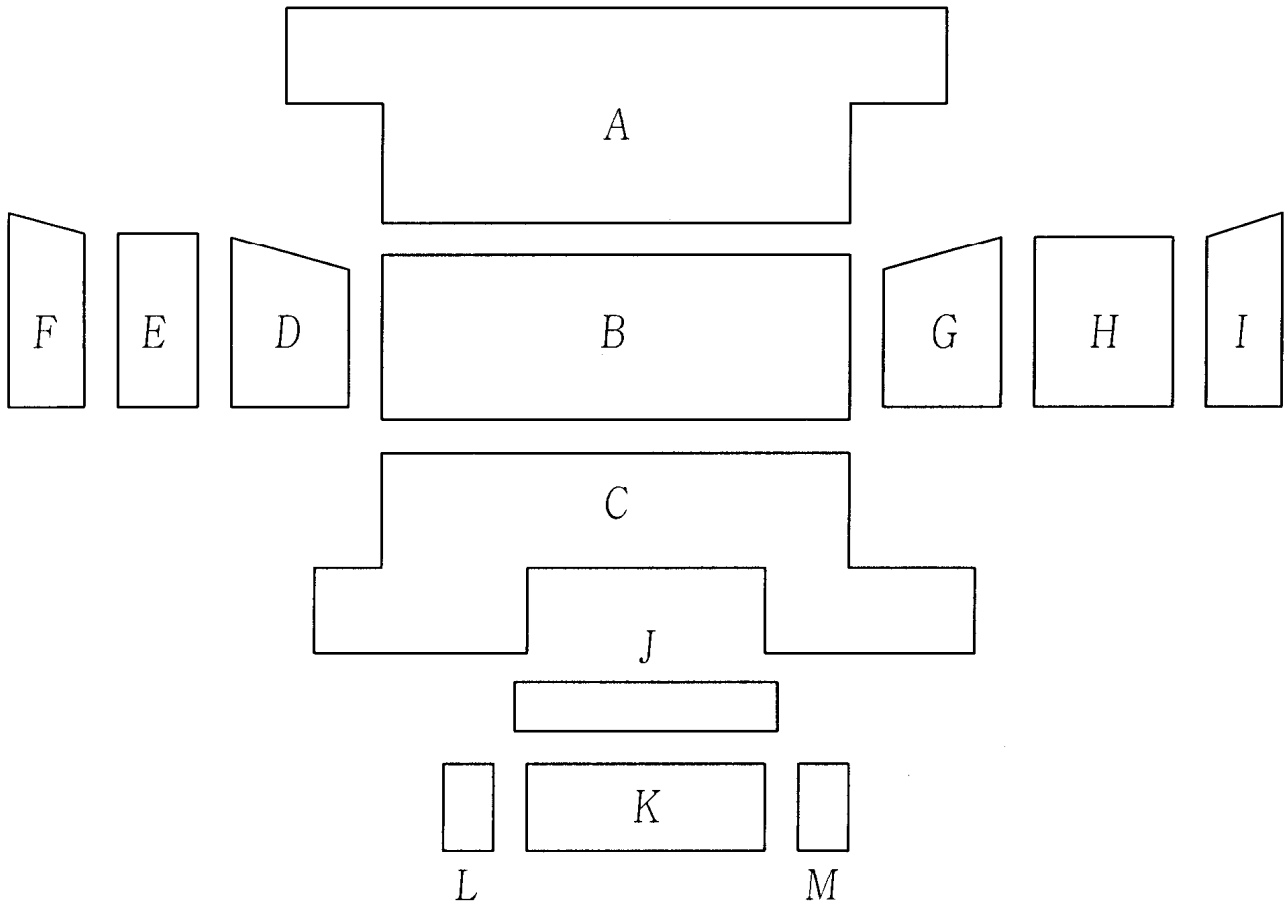

DIMENSIONS

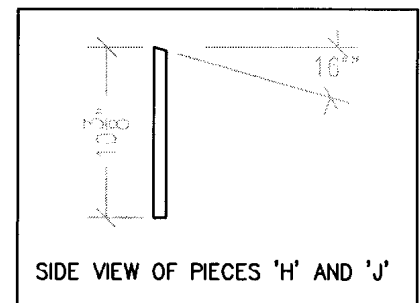
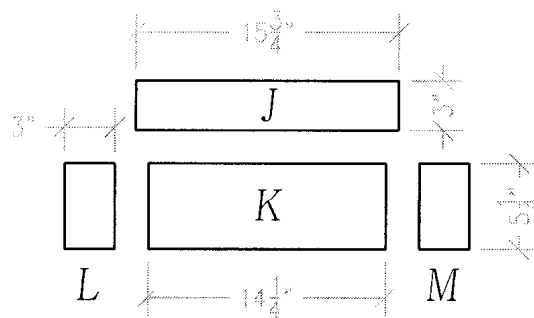
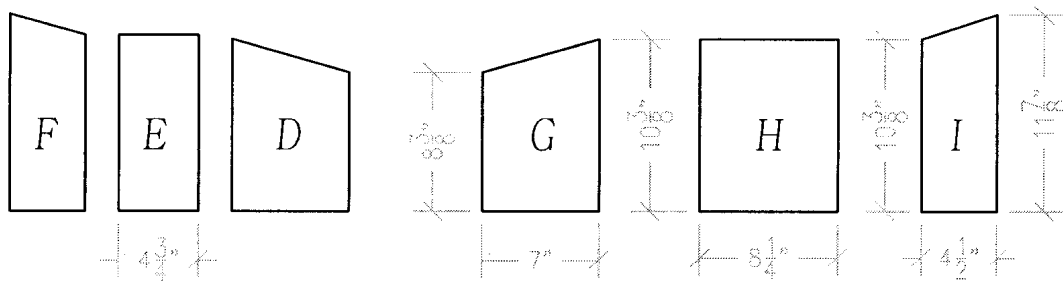
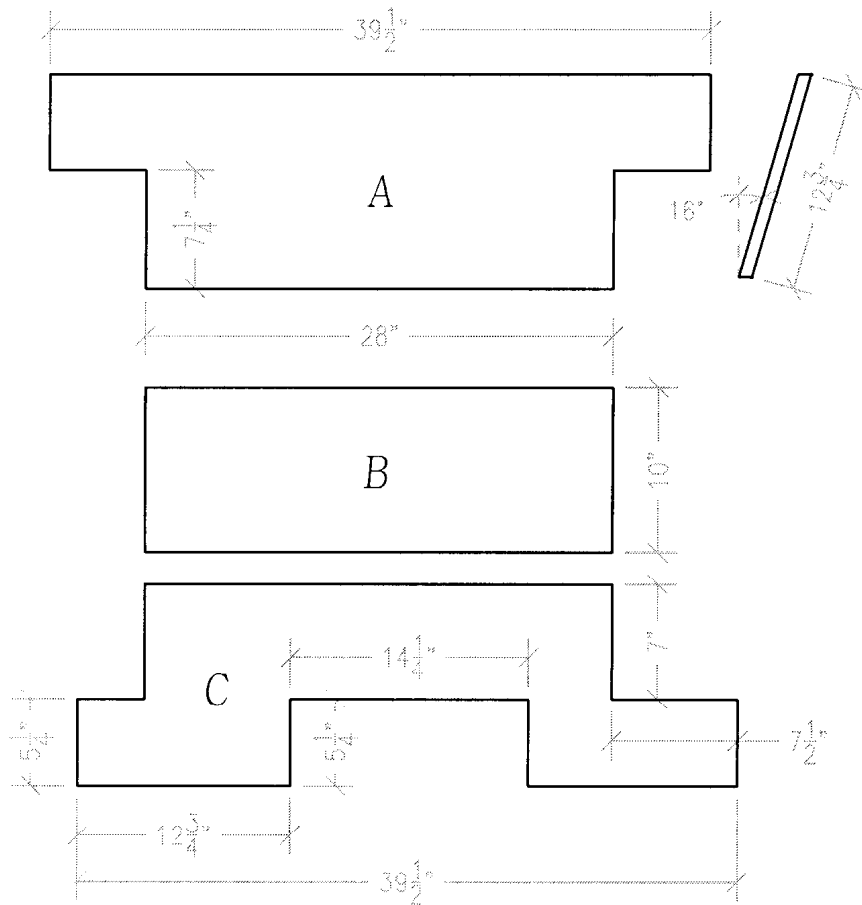

- * PIECE 'D' IS IDENTICAL TO PIECE 'G'
- PIECE 'F' IS IDENTICAL TO PIECE 'I'.
- PIECE 'L' IS IDENTICAL TO PIECE 'M'.

INSTRUCTIONS

(Some screw locations not shown, see tip sheet for screw placement suggestions)

1. Start by cutting pieces J, K, L, and M. Pre-drill and assemble these pieces as shown.

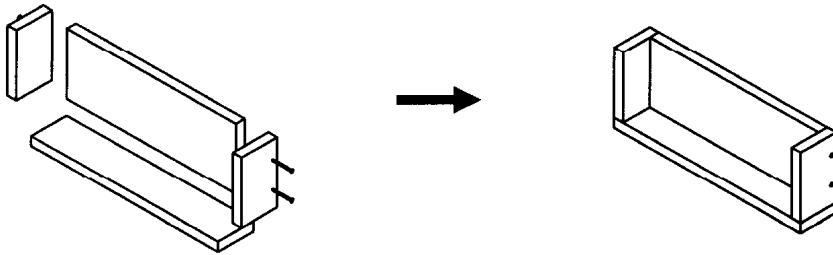

2. Cut out piece 'C' (Rectangle Only), and attach the JKLM assembly as shown.

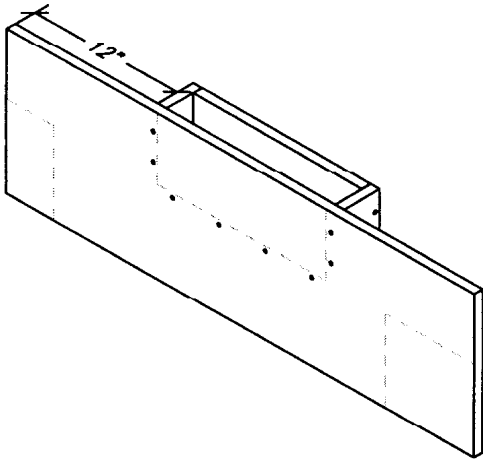

3. Cut out piece 'B' and attach as shown.

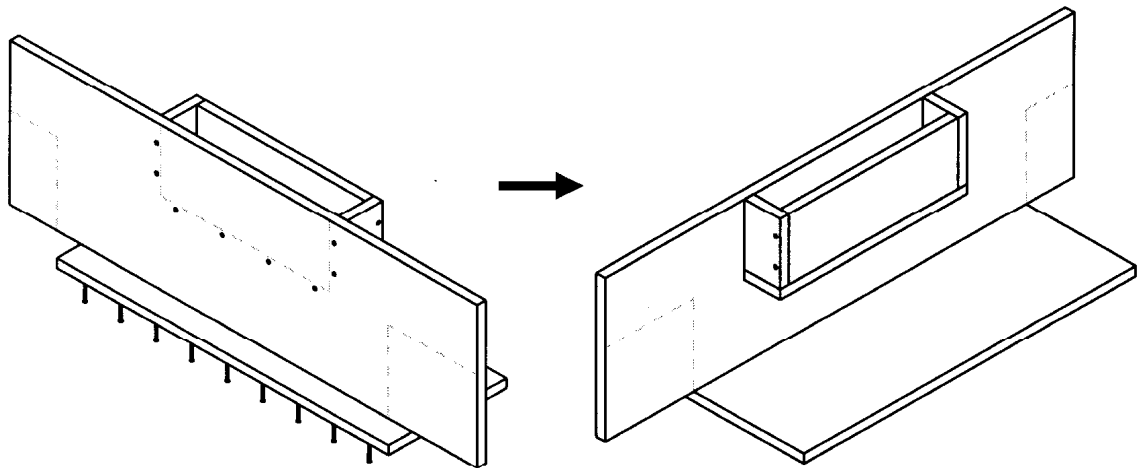

INSTRUCTIONS

4. Cut pieces D, and G, and attach.

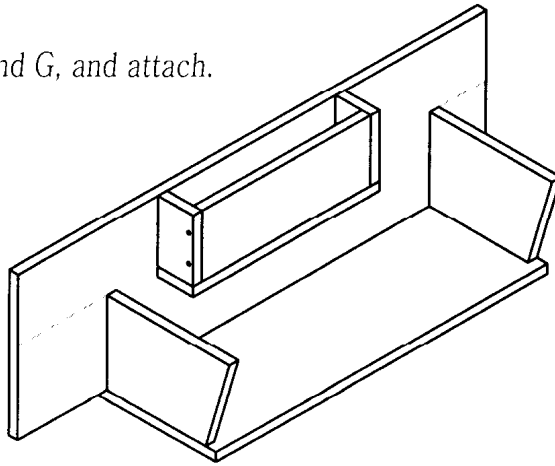

5. You should now be able to check the required length of piece 'A'. The dimension provided should be accurate, but it's a good idea to double-check because this piece has an angle on each end, and any deviation in one of the previous cuts could change the required length of this piece. Cut piece 'A' (rectangle only) and attach.

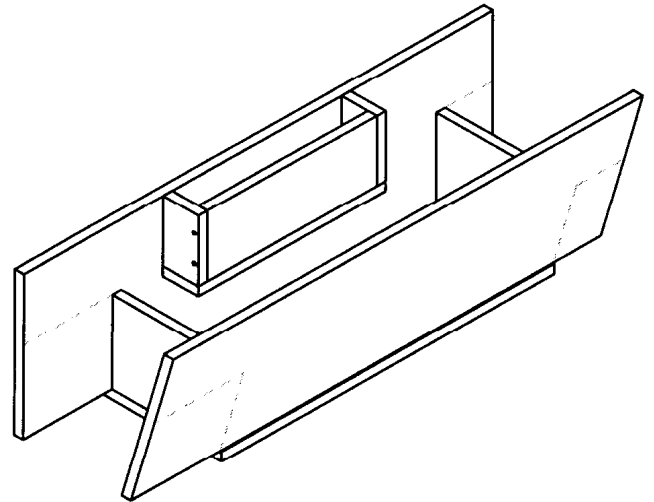
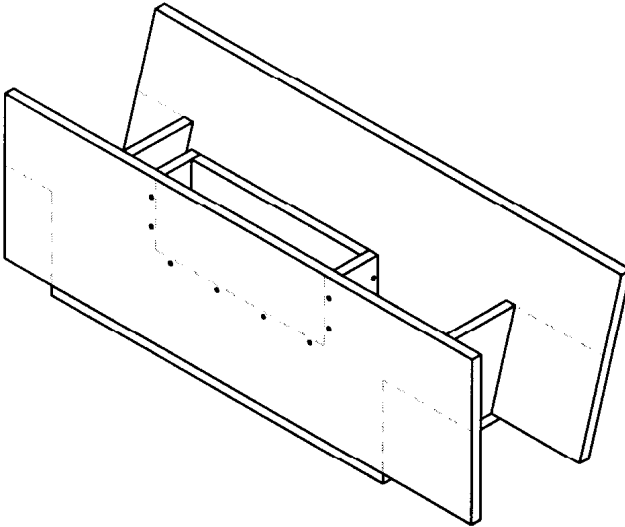

6. Cut pieces G, and H, and attach as shown.

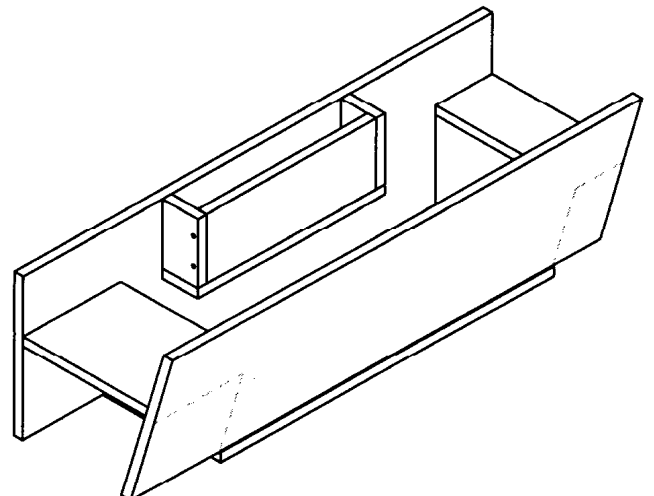
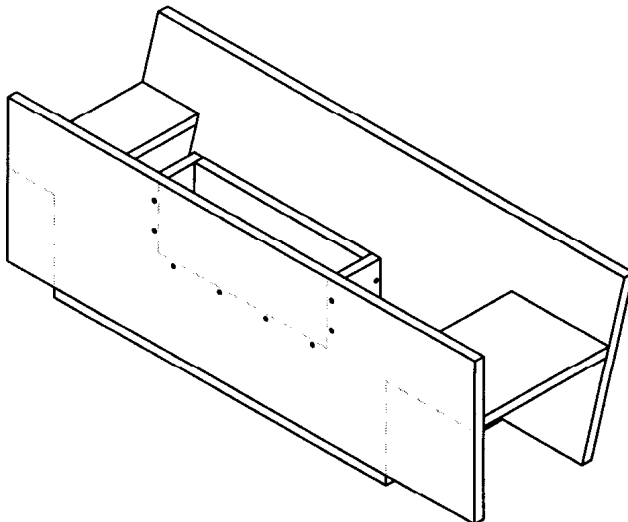

INSTRUCTIONS

7. Cut pieces F, and I, and attach as shown.

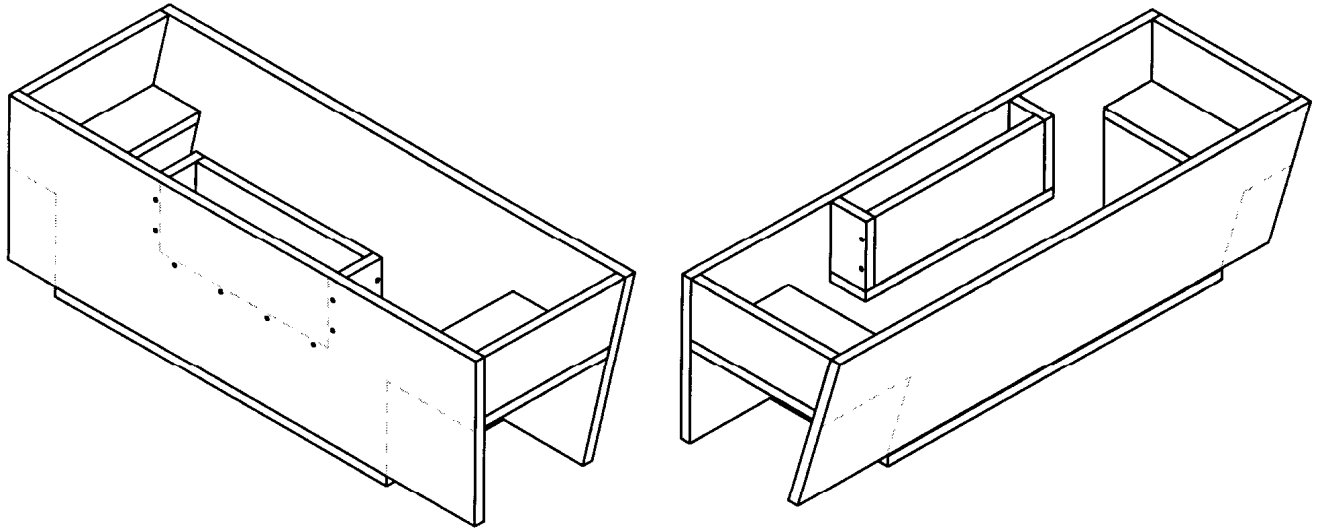

8. Now that most of the enclosure is assembled, trim out the void areas of pieces 'A' and 'C'. The labeled 'N' can be rounded with a router or file to help fit the enclosure into the car more easily.

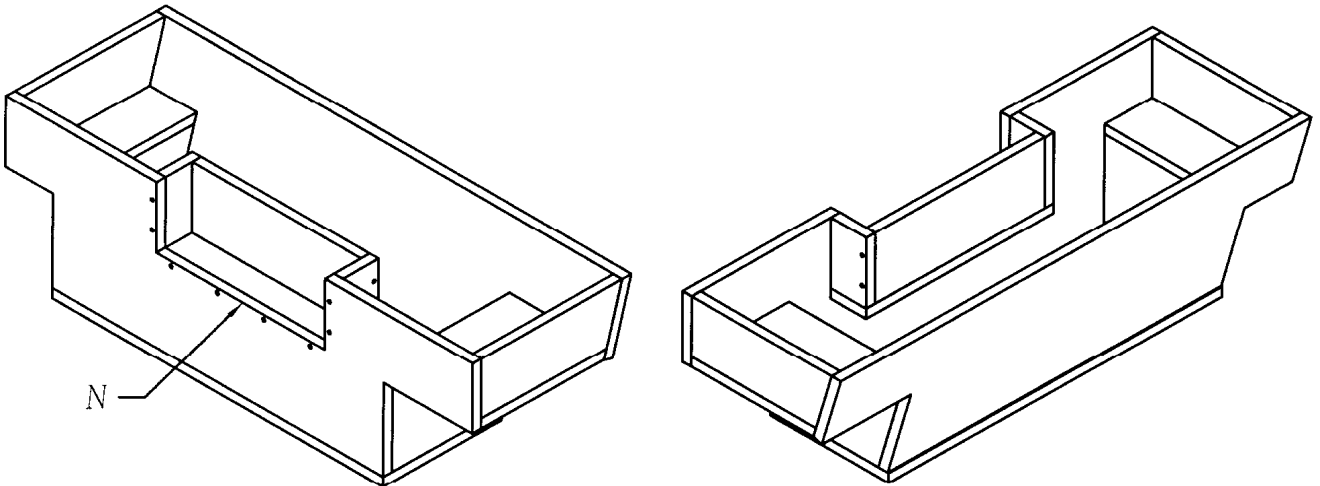

9. Now is a good time to test fit the box in the well. It will appear not to fit, however by tilting the top of the box toward the front of the car and rocking it back and forth, it will slide down and fit securely into the well. A good amount of force is required to seat the box and remove it. Adjust the enclosure if necessary to fit properly.
10. Use the template to cut out the top plate of the box. The easiest way is to use spray adhesive to temporarily glue the template to the MDF, then simply cut along the line with a Jigsaw.
11. With the enclosure still in the car, place the top plate on the box and make necessary adjustments to get a good fit.

INSTRUCTIONS

12. Position the top plate where it fits best on the box. The template box outline may be helpful in doing this. Once you know where to align the enclosure and top plate, remove them from the car and attach the top plate to the enclosure.
13. Using the template, cut the mounting holes for your particular size subwoofer(s).
14. Cut the holes for your speaker terminal(s).

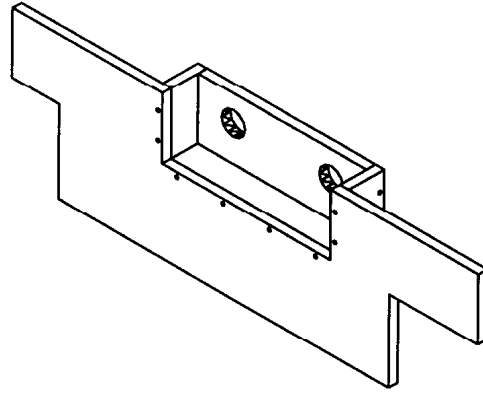

15. Make pencil marks at each joint on the enclosure so you can fit the pieces exactly as they are after disassembling them. Once this is done, disassemble the enclosure.
16. Reassemble the enclosure this time using the sealant at each joint. Use the Tips sheet as a guide if you are unfamiliar with this process.
17. Before carpeting the top plate, test fit your subwoofer(s) and make any necessary adjustments to the mounting hole(s). If your subwoofers are too deep to fit properly, you will need to make a MDF baffle to raise the subwoofers to the right height.

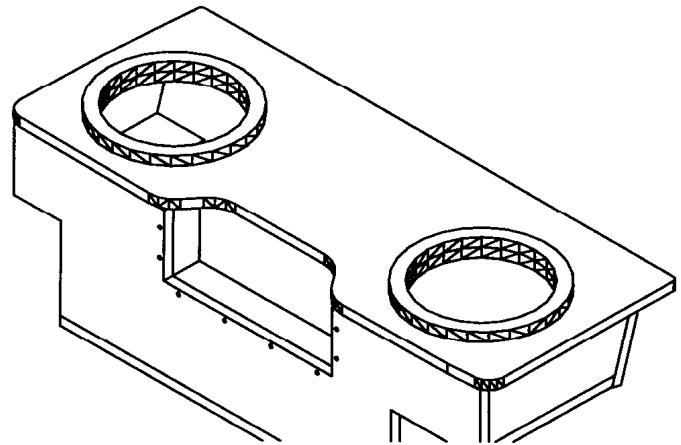

18. Now you can carpet the top of the box. Be sure and use a quality adhesive. At least 3M-90 or equivalent is recommended.
19. Because of the difficulty in getting the enclosure in and out of the vehicle, it is recommended that the enclosure be pre-wired and placed in the car before mounting the subwoofer(s).

* Allow the sealant to dry at least 24 hours prior to playing the subwoofers to ensure a good seal.